

## Installation guide

### Mignon pressure reducers - art. 247-248



## 1. INSTALLATION

For correct installation, open all the supply taps to facilitate cleaning of the system and to expel any air remaining in the pipes.

We recommend the installation of shut-off valves upstream and downstream to facilitate any future maintenance operations.

After closing the shut-off valve downstream, it is possible to perform calibration by unscrewing the plastic cap and moving the screw located on the top of the large screw (Fig.1). Using a screwdriver of adequate size, turn clockwise to increase the calibration pressure and anti-clockwise to decrease it.

The set value can be displayed using a pressure gauge.

Models 247 – 248 have a factory calibration of 3 bar.

Installation of the reducer can be performed in any position except upside down (Fig.2).

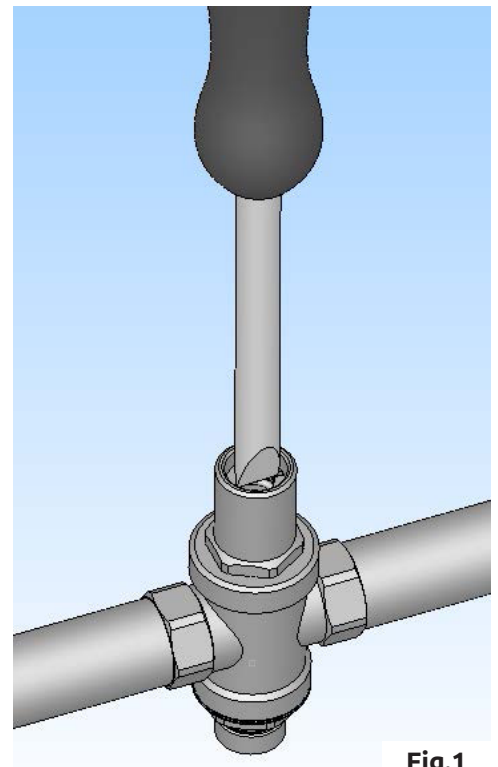
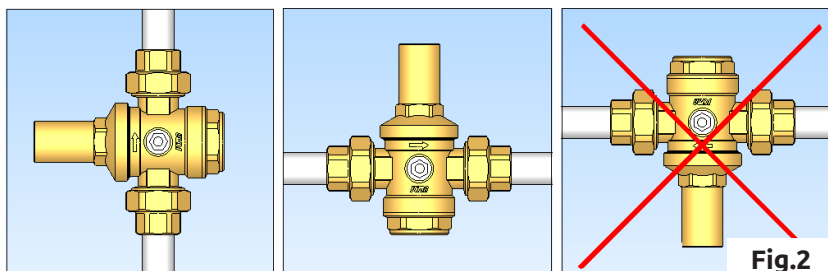

## 2. FUNCTIONAL ANOMALIES AND INSTALLATION TIPS

Some of the anomalies that are normally attributed to pressure reducers are often caused by the lack of appropriate plant engineering measures. Below are the most frequent cases:

### The reducer does not maintain the set calibration value

In most cases the problem is the result of the presence of impurities that, remaining on the sealing seat, cause leakage and possible increases in pressure downstream. To resolve this malfunction, it is advisable to install a filter upstream of the reducer. The figure shows the ICMA Art 50 Oblique filter used to collect impurities (Fig.3)

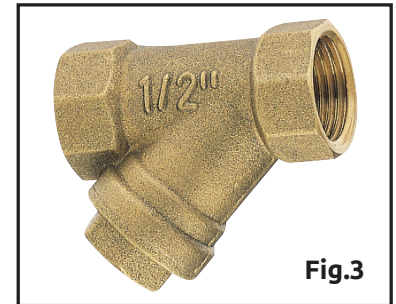

Fig.3

### In the presence of a boiler there is an increase in the pressure downstream of the reducer

The problem is due to the fact that the boiler causes overheating of the water resulting in a subsequent increase in pressure also due to the fact that in this case the reducer is in the closed position.

To absorb the increase in pressure, the solution is to install an expansion tank between the reducer and the boiler.

It is advisable to install the pressure regulators inside wells or in technical rooms, the main reasons being are the risk that frost may cause breakages, to facilitate reading of the pressure gauge and to facilitate inspection and maintenance operations.

## 3. WATER HAMMER

To avoid breaking the pressure reducers installed in systems at risk, it is advisable to use specific components in order to absorb so-called "water hammer", thus avoiding possible damage.

## 4. SAFETY



Carefully read the assembly and commissioning instructions before operating the appliance in order to avoid accidents and system faults caused by improper use of the product. Please note that the right to the warranty expires in the event that unauthorised modifications or tampering take place during the assembly and construction phase.

## 5. OPERATING CONDITIONS

The limit values indicated must never be exceeded. Operating safety is therefore ensured by complying with the general conditions and operating limit values described in this sheet.

## 6. SAFETY RULES FOR ASSEMBLY AND INSPECTION

The assembly and inspection operations must always be performed by qualified, authorised personnel, who are aware of the instructions provided in this sheet. Before any work on the equipment it is necessary to ensure that it is in a rest condition.

## 7. MAINTENANCE

Maintenance operations must always be performed by qualified, authorised personnel, who are aware of the instructions provided in this sheet. Before any work on the equipment it is necessary to ensure that it is in a rest condition.

## 5. DISASSEMBLY, DEACTIVATION AND SCRAPPING

At the end of the product's service life, before disposing of it permanently, think about whether it can be used for other purposes.

If it is necessary to dispose of it, disassemble it when the system is stopped, using the wrenches indicated in the installation chapter.

The demolition and disposal of the product are the sole responsibility of the owner, who must act in compliance with the laws in force in their country regarding safety and environmental protection. At the end of its useful life, the product must not be disposed of together with municipal waste. It can be delivered to the appropriate separate collection centres set up by the municipal administrations or to specific retailers that provide this service.

Disposing of the product in a differentiated manner prevents possible negative consequences for the environment and health, resulting from its inadequate disposal, and facilitates recovery of the materials of which it is composed in order to obtain important saving of energy and resources.

*We reserve the right to make improvements and changes to the described products and related technical data at any time and without notice. The information contained in this technical communication does not exempt the user from strictly following the existing regulations and standards of good technique. ICMA SpA declines all responsibility in the event of faults and/or accidents if the installation has not been performed in accordance with the technical and scientific standards in force and referring to the manuals, catalogues and/or related technical provisions indicated by ICMA SpA.*