

/ Description

Valves with thermostatic option are used to regulate and cut-off the flow of the heat transfer fluid that circulates inside airconditioning system terminals (radiators, fan coils, etc.). Thermostat control devices are used in combination with the valves with thermostatic option to automatically regulate ambient temperature wherever they are installed, keeping the temperature at a preset value. This avoids the needless wasting of heat and provides a considerable saving of energy.



/ Valves with thermostatic option - copper, multilayer, Pe-x

Article	Type	Pipe fitting	Radiator
1110 - Valves with thermostatic option	Angled	M24x1,5	G1/2" - G3/8"
1122 - Valves with thermostatic option*	Angled	M24x1,5	G1/2" - G3/8"
1134 - Valves with thermostatic option	Angled	M24x1,5	G1/2" - G3/8"
1111 - Valves with thermostatic option	Straight	M24x1,5	G1/2" - G3/8"
1123 - Valves with thermostatic option*	Straight	M24x1,5	G1/2" - G3/8"
1152 - Valves with thermostatic option	Straight	M24x1,5	G1/2" - G3/8"

/ Valves with thermostatic option - iron pipe

Article	Type	Pipe fitting e Radiator
1112 - Valves with thermostatic option	Angled	G1/2"
1124 - Valves with thermostatic option*	Angled	G1/2"
1156 - Valves with thermostatic option	Angled	G1/2"
1113 - Valves with thermostatic option	Straight	G1/2"
1125 - Valves with thermostatic option*	Straight	G1/2"
1154 - Valves with thermostatic option	Straight	G1/2"

*Available variant with chromed radiator connection and nut

/ Thermostat control devices

Article	Code	Connection
1099 - Thermostat control device with built-in sensor, with liquid-sensitive component	821099AC07	M28x1,5
1100 - Thermostat control device with built-in sensor, with liquid-sensitive component	821100AC20	M28x1,5
1151 - Thermostat control device with built-in sensor, with liquid-sensitive component	821151AC09	M28x1,5

/ Matching fittings

For heating systems with copper, polyethylene or multi-layer polyethylene pipes, use the following fittings to connect ICMA valves with thermostatic option to the heating system:

Article	Fitting thread
90 - Patented SICURBLOC fitting for copper pipe	G1/2" - M24x1,5
91 - Patented SICURBLOC fitting for copper pipe	M24x1,5
98 - Fitting for multi-layer, Pe-x	G1/2"
100 - Fitting for multi-layer, Pe-x	M24x1,5
95 - Fitting for multi-layer, Pe-x	M24x1,5

/ Valves with thermostatic options

ICMA thermostat control devices can be installed on all Valves with thermostatic options of this line to convert heating systems with manual operating mode to automatic operating mode.

To install the thermostat control device, simply replace the Valves with thermostatic option knob with an ICMA thermostat control device. This is done with a few easy operations. These are described in detail in the paragraph "Thermostat Control Device Installation and Regulation".

The valves come in "straight" and "angled" versions so that they can be connected to two different types of pipes, at the side of the heating system:

- The valves with GAS thread (side of heating system) are designed for connection to a steel pipe.
- The valves with standard ICMA thread (side of heating system) are designed for connection to a copper pipe, a polyethylene pipe and a multi-layer polyethylene pipe, for which specific pipe fittings are provided.

The valves are also equipped with a rubber, water-sealed socket. This allows the valve to be connected to the radiator easily and safely without the use of a sealant. Pressure loss can be detected by following the indications provided in the diagrams shown in the paragraph "Fluid Dynamic Characteristics".

/ Technical specifications

Performance

Fluids used:	water and glycol solutions
Maximum percentage of glycol	50%
Maximum operating pressure:	10 Bar
Maximum differential pressure:	1 Bar (with control device mounted)
Temperature of heat transfer fluid:	5 ÷ 120°C
Valve obturator travel:	3,5 mm
Connection with thermostat control devices:	28 x 1,5

Materials

Body, cap and socket union:	brass CW617N - UNI 12165
Finish:	chromed, white, matt black
Large screw:	brass CW617N - UNI 12165
Spring and obturator control rod:	stainless steel
Hydraulic sealing:	EPDM Perox
Control knob:	ABS

/ Valve installation

Install ICMA Valves with thermostatic options on the heating IC system making sure to observe the direction of flow. The fluid must enter from the side on which the valve is connected to the system and go out toward the heating body.

The following problems can occur if the valve is installed incorrectly:

- A noise similar to a continuous sound of heavy hammering is due to the passage of fluid through the valve in the wrong direction. This problem can only be solved by inverting the valve with holder on radiators that have this problem, thus restoring the correct direction of flow of the fluid inside the valve.

- A noise similar to a sound of heavy whistling during the succession of specified on and off times is due to an excessive flow inside the valve. This problem can be solved by keeping the system pressure under control, and equipping the system with variable rotation pumps along with differential pressure regulators, or by making use of differential by-pass valves.

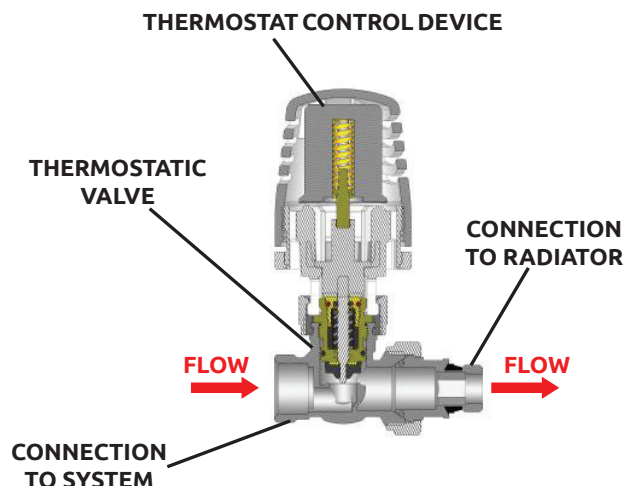
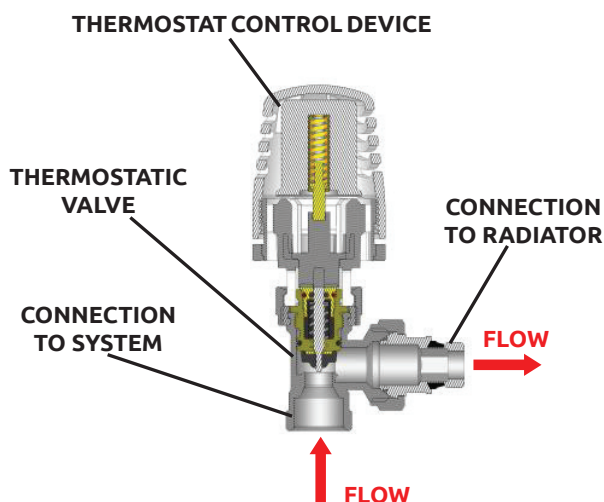

/ Thermostat control device

Thermostat control devices are used to regulate ambient temperatures automatically wherever they are installed so that the temperature is kept at a preset value.

Residential and working environments often contain other sources of heat, such as electrical appliances, stove-top cookers, computers, servers, and simple sunlight. Combined with the heating system, these additional heat sources cause a needless, uncontrolled increase in ambient temperature and the wasting of heat. Thermostat control devices detect variations in ambient temperature in the environments in which they are installed making it possible to keep the heat supplied by the heating system at optimal temperatures and to provide a considerable saving of energy.

The ICMA thermostat control device can be installed on all Valves with thermostatic options of this line.

ICMA valves are supplied with the current manual control knob (for manual operation).

The valves can be converted into thermostatic valves that function completely automatically by installing a thermostat control device.

To install the thermostat control device, simply remove the Valves with thermostatic option control knob and replace it with the thermostat control device. This is done with just a few easy operations. These are described in detail in the paragraph "Thermostat Control Device Installation and Regulation".



/ Adjustment scale

Adjustment scale: ❄ ÷ 5

Temperature adjustment range: 7 ÷ 28°C

The asterisk ❄ indicates the freezing protection position, which corresponds to 7°C.

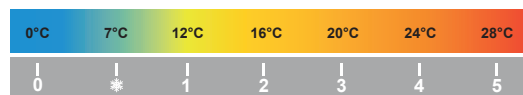

/ Technical specification

Performance

Minimum adjustment calibration (antifreeze position):	ts min 7°C (❄)
Maximum adjustment calibration (position):	ts max 28°C (5)
Saving condition (position):	20°C (3)
Maximum working pressure:	PN 1000 KPa
Maximum differential pressure:	Δp 100 KPa
Nominal capacity "qm N" angled-straight:	qm N 190 Kg/h
Maximum working temperature:	110°C
Maximum storage temperature:	50°C
Hysteresis:	C 0.25 K
Authority:	a 0,9
Response time:	Z 20 min
Differential pressure influence:	D 0,25 K
Water temperature influence:	W 0,7 K
Use of the protection cap:	55°≈1K
Connection to Valves with thermostatic options:	M28x1,5
Certification:	UNI - EN215

The thermostatic valve is fitted with manual adjustment handwheel (rotation)

Materials

Knob and stop ring:	ABS
Finish:	chromed, white, black matt
Body and transmitter:	PA6 30% F.V.
Sensor liquid:	Thermostatic ethyl-acetate
Connection ring:	Brass CW617N - UNI 12164 - Nickel-plated
Compensation pin:	Brass CW617N - UNI 12164
Compensation pin spring:	SH steel for springs - Phosphated

/ Operation

The thermostat head is made of a series of plastic parts containing a thermostatic component that is sensitive to temperature variations.

Operation of the thermostatic component is based on the expansion of the thermostatic liquid contained inside it:

- when the ambient temperature rises, the thermostatic liquid increases in volume, resulting in the lengthening of the component;
- when the ambient temperature drops, the thermostatic liquid decreases in volume, resulting in the shortening of the component.

The variations in length of the thermostatic component are transmitted to the expansion valve obturator by a small steel rod. These movements constantly regulate the flow of the heat transfer fluid to the heating component so that the temperature set on the thermostat control device remains constant over time.

CLOSED VALVE

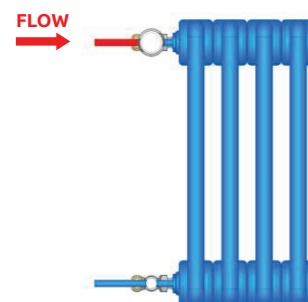

OPEN VALVE

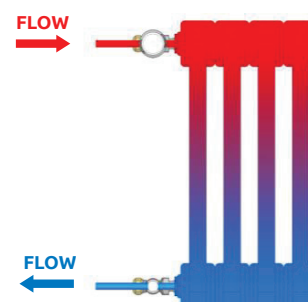

The thermostat control device components are specially made of plastic materials to prevent the valve heat and that irradiated by the heating component from being transmitted to the thermostatic component by contact or induction. This prevents possible malfunctions in the control device.

The thermostat control device temperature is regulated by turning the numbered knob and bringing the corresponding symbol to the desired temperature close to the head indicator (see the following paragraph for more details).

- Position 3 on the adjustment scale corresponds to an ambient temperature of 20°C. This is the recommended temperature for ensuring a comfortable environment and reduced heat consumption and costs.

- The asterisk “*” indicates the freezing protection position. When the thermostat control device is set to this position, the valve turns on only if the ambient temperature drops below 6°C.

This setting is recommended when one is absent for long period of time during the winter months, or when one wishes to aerate the premises when outside temperatures are very low.

/ Orientation of thermostat control device

The ICMA thermostat control devices should be installed in the horizontal position. Any other position could compromise their correct functioning.

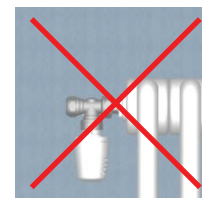
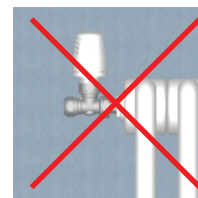
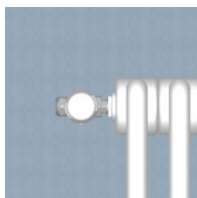

/ Positioning of radiators

The thermostat control devices should never be placed inside niches or radiator boxes, behind curtains or exposed to direct sunlight. These conditions could result in incorrect detection of the actual ambient temperature and compromise the proper functioning of the device.

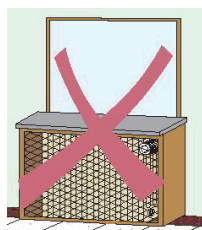

Thermostat control device installation and regulation

Conversion of manual valves to thermostatic valves

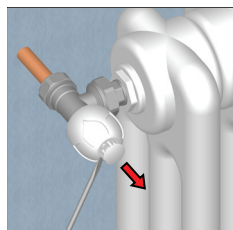

Remove the protective cover from the knob using a small screwdriver.

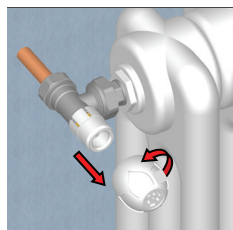

Turn the knob in the counter clockwise direction to remove it completely from the valve.

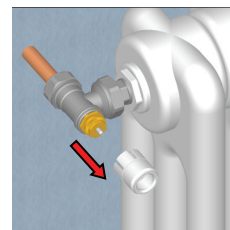

Unfasten the white adapter from the valve body by simultaneously pulling and bending it.

Installation of thermostatic control device

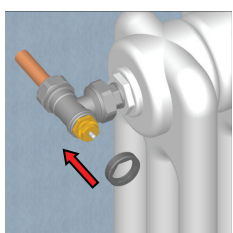

Mount the grey ring supplied with the thermostat control device on the valve body. Keep the hexagonal socket turned toward the operator.

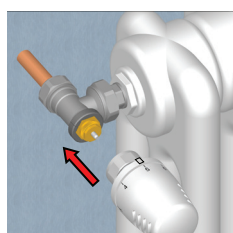

Set the control device to setting 5 and install the device on the valve body. Keep the indicator turned upward so that it is clearly visible.

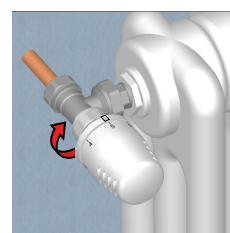

Fasten the thermostat control device to the valve and screw the chromeplated ring completely onto the grey ring. Tighten with suitable wrench.



If the use of tools for screwing is necessary, place a soft cloth over the ring to prevent damage to the decorated surfaces.



Temperature adjustment

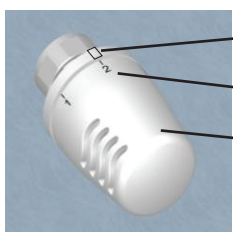

INDICATOR
ADJUSTMENT SCALE
KNOB

The knob indicates the numbers from 0 to 5, which correspond to specific temperatures (see the adjustment scale shown at side). Set the desired temperature simply by turning the knob to the corresponding number close to the indicator.

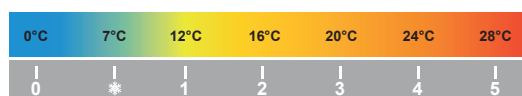

Blocking of temperature



Turn the thermostat control device knob to one of the setting numbers from 0 to 5 shown on the knob. Setting example on the n°2.

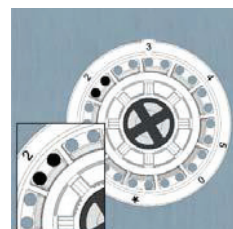

The same numbering is also indicated on the lower part of the device. Identify the hole before and the hole after the number set.



Insert the forked pin inside these two holes and push until completely inserted. The knob is now blocked at the desired setting.

Limitation of temperature

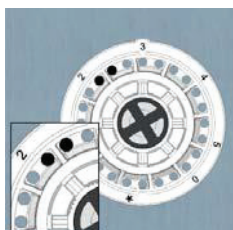

In order to limit the temperature, simply identify the two holes located right after the number set.



Insert the forked pin inside these two holes and push until completely inserted. The knob can now be move from 0 to the number set.



The forked pin is sold separately from the control device.

FORKED PIN CODE: 111100AC06

/ Dimensions and codes articles

Valves with thermostatic options - copper, multilayer, Pe-x

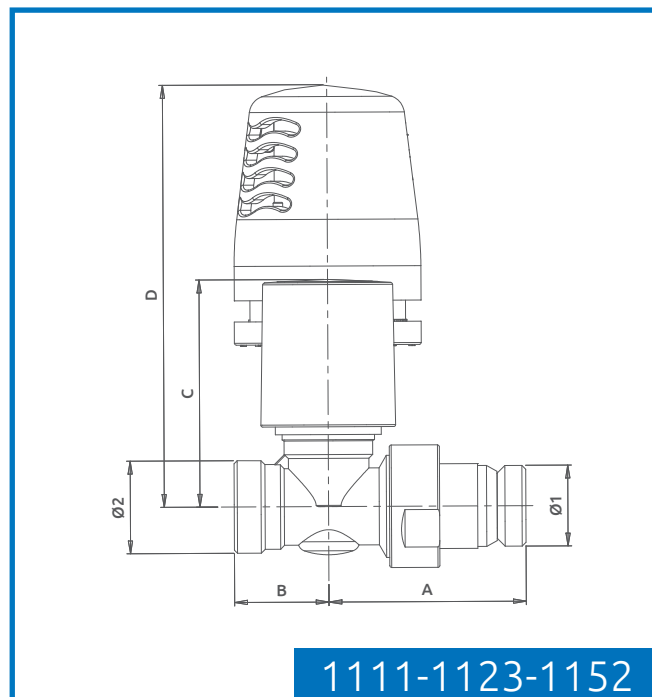
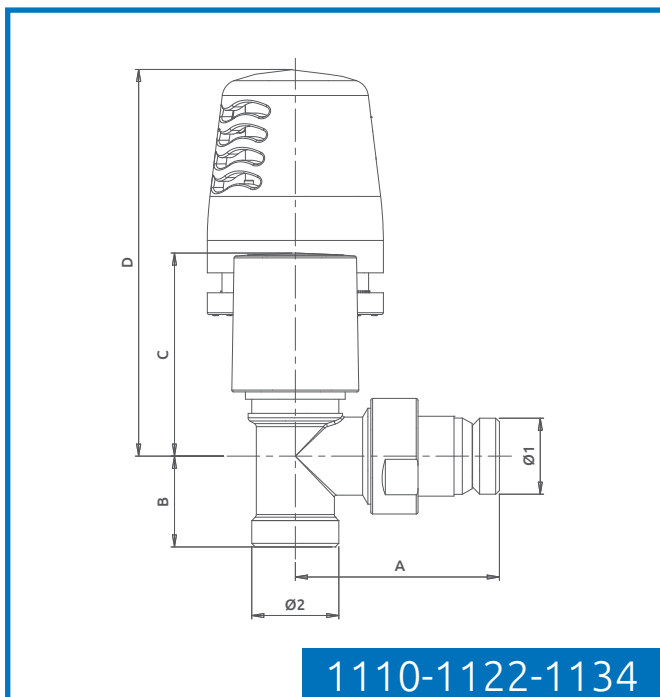

CODE	Ø1	Ø2	A	B	C	D
821110AC07	G3/8"	M24x1,5	56	25	56	106,5
821110AD07	G1/2"	M24x1,5	56	25	56	106,5
821122AC13	G3/8"	M24x1,5	56	25	56	106,5
821122AD13	G1/2"	M24x1,5	56	25	56	106,5
821122AC1307*	G3/8"	M24x1,5	56	25	56	106,5
821122AD1307*	G1/2"	M24x1,5	56	25	56	106,5
821134AC09	G3/8"	M24x1,5	56	25	56	106,5
821134AD09	G1/2"	M24x1,5	56	25	56	106,5

CODE	Ø1	Ø2	A	B	C	D
821111AC07	G3/8"	M24x1,5	51	24,5	59	109,5
821111AD07	G1/2"	M24x1,5	51	24,5	59	109,5
821123AC13	G3/8"	M24x1,5	51	24,5	59	109,5
821123AD13	G1/2"	M24x1,5	51	24,5	59	109,5
821123AC1307*	G3/8"	M24x1,5	51	24,5	59	109,5
821123AD1307*	G1/2"	M24x1,5	51	24,5	59	109,5
821152AC09	G3/8"	M24x1,5	51	24,5	59	109,5
821152AD09	G1/2"	M24x1,5	51	24,5	59	109,5

*White finish with chromed radiator connection and nut.

Valves with thermostatic options - iron pipe

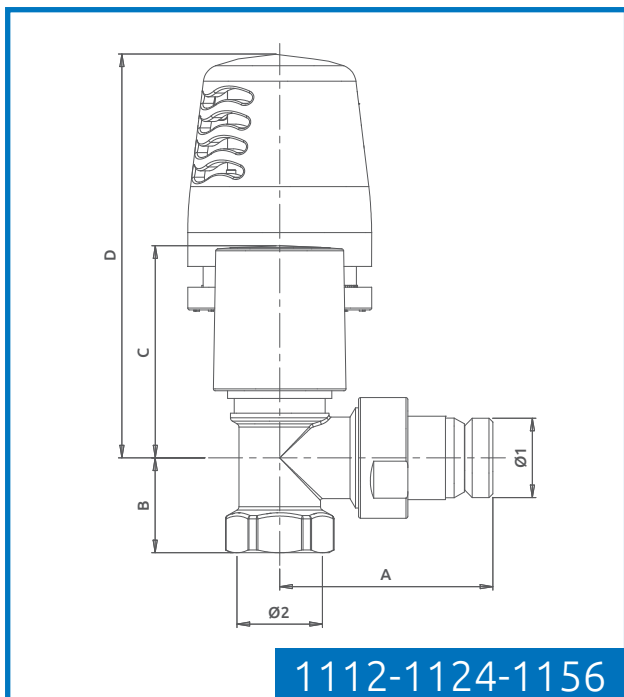

1112-1124-1156

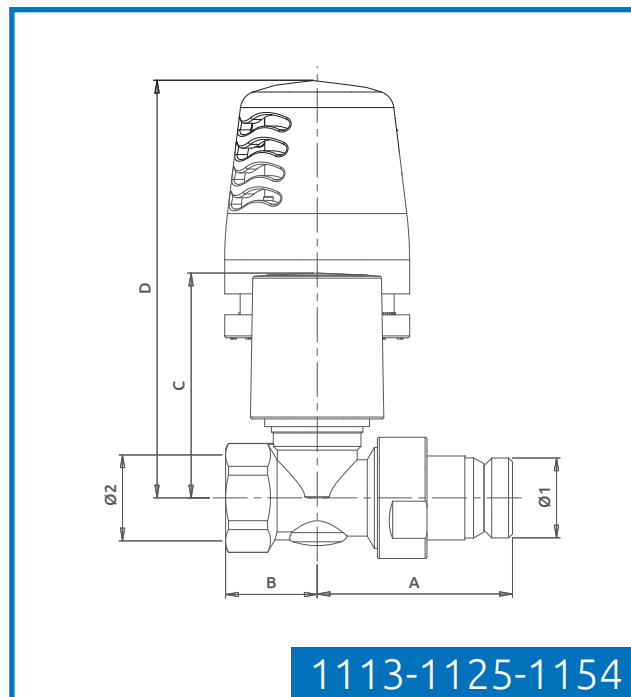

1113-1125-1154

CODE	Ø1	Ø2	A	B	C	D
821112AD07	G1/2"	G1/2"	56	25	56	106,5
821124AD13	G1/2"	G1/2"	56	25	56	106,5
821124AD1307*	G1/2"	G1/2"	56	25	56	106,5
821156AD09	G1/2"	G1/2"	56	25	56	106,5

CODE	Ø1	Ø2	A	B	C	D
821113AD07	G1/2"	G1/2"	51	24	59	109,5
821125AD13	G1/2"	G1/2"	51	24	59	109,5
821125AD1307*	G1/2"	G1/2"	51	24	59	109,5
821154AD09	G1/2"	G1/2"	51	24	59	109,5

*White finish with chromed radiator connection and nut.

Hydraulic Specifications

Angle valves with thermostatic option G3/8" - Art. 1110-1122-1134-1152-1156

PRESSURE DROP DIAGRAM

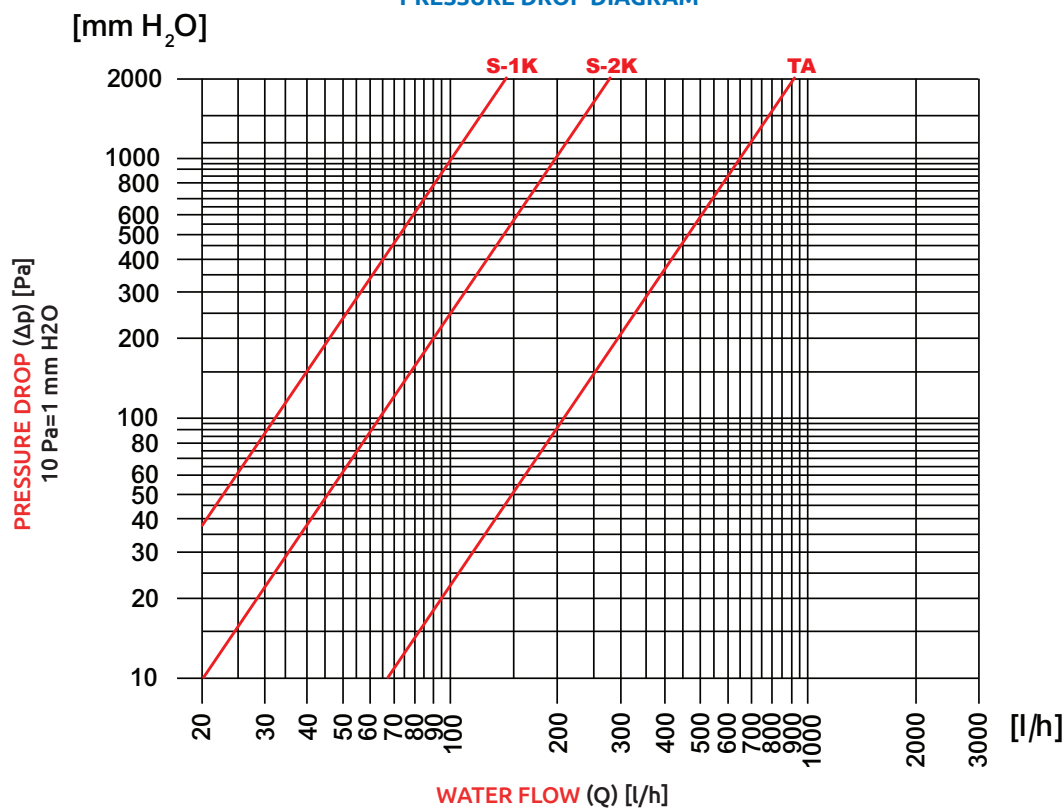

Kv [m ³ /h]	
TA	2,11
S-2K	0,60
S-1K	0,33

Angle valves with thermostatic option G1/2" - Art. 1110-1122-1112-1124-1134-1152-1156

PRESSURE DROP DIAGRAM

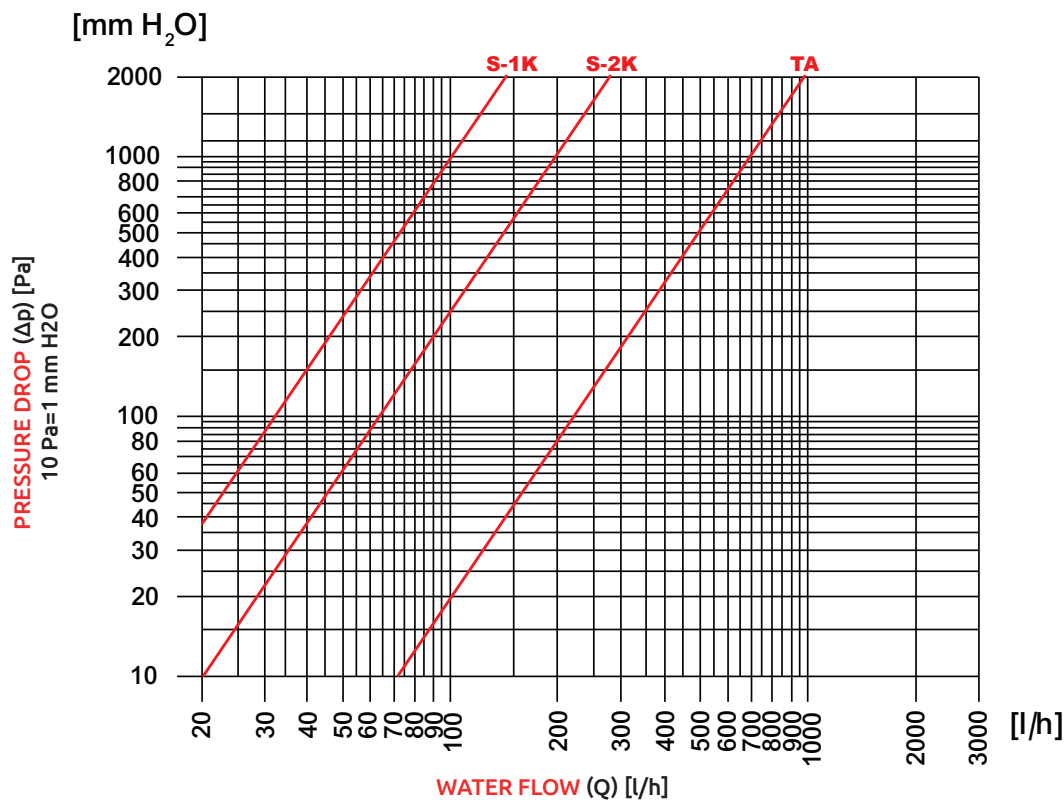

Kv [m ³ /h]	
TA	2,21
S-2K	0,60
S-1K	0,33

Angle valves with thermostatic option G3/8" - Art. 1111-1123-1152

PRESSURE DROP DIAGRAM

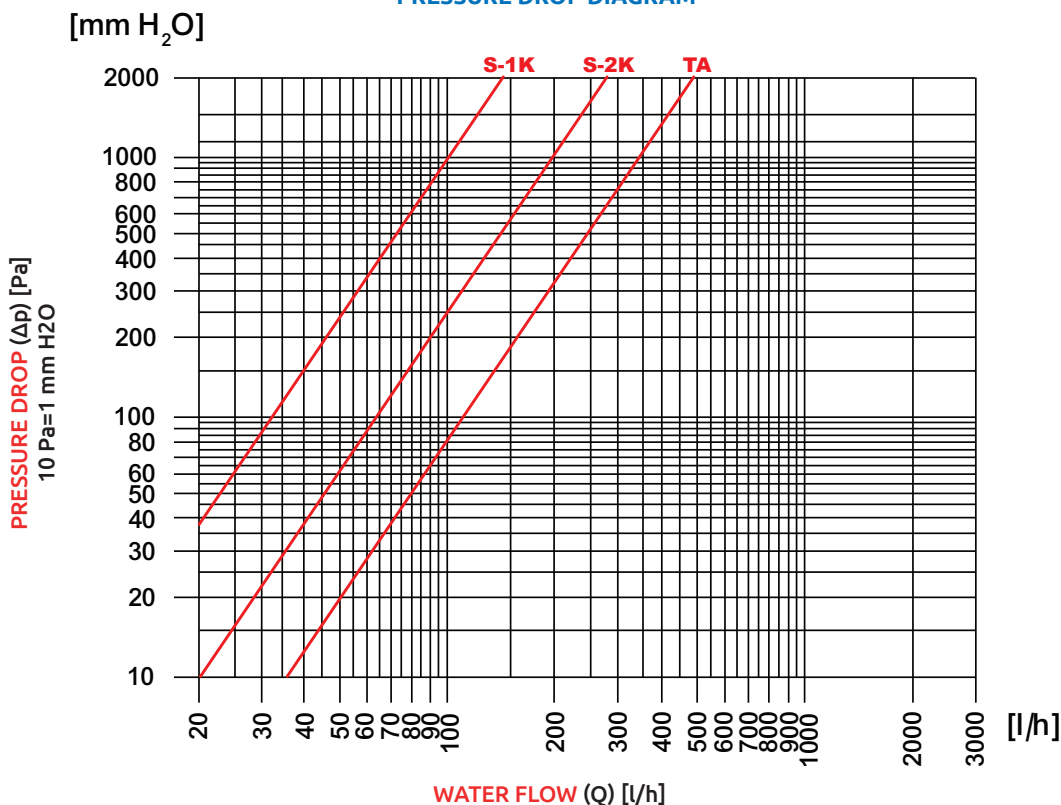

Angle valves with thermostatic option G1/2" - Art. 1111-1123-1113-1125-1152-1154

PRESSURE DROP DIAGRAM

