

Description

Thermostatic expansion valves are used to regulate and cut-off the flow of the heat transfer fluid that circulates inside air-conditioning system terminals (radiators, fan coils, etc.).

Thermostat control devices are used in combination with the thermostatic expansion valves to automatically regulate ambient temperature wherever they are installed, keeping the temperature at a preset value. This avoids the needless wasting of heat and provides a considerable saving of energy. On all thermostatable valves in our "hydrothermal system" range, our thermostatic controls can be installed, from a first manual operation condition to automatic operation.

To do this, simply replace the thermostatically controlled control knob with one of our control thermostats, the operations to be performed are simple and detailed, in detail in the "Installation" section of the thermostat.

THERMOSTATIC VALVES



LOCKSHIELDS



THERMOSTATIC CONTROL DEVICE



Product range

DOUBLE ANGLE THERMOSTATIC VALVES – COPPER, MULTI-LAYER, POLYETHYLENE PIPE

Article	Type	Pipe fitting	Radiator
1140	Double Angled	24x1,5	G 1/2" M
1146	Double Angled	24x1,5	G 1/2" M
1148	Double Angled	24x1,5	G 1/2" M

DOUBLE ANGLE LOCKSHIELD – COPPER, MULTI-LAYER, POLYETHYLENE PIPE

Article	Type	Pipe fitting	Radiator
1143	Double Angled	24x1,5	G 1/2" M
1147	Double Angled	24x1,5	G 1/2" M
1149	Double Angled	24x1,5	G 1/2" M

THERMOSTATIC CONTROL DEVICE

Article	Code	Connection
1099	821099AC07	M28x1,5
1100	821100AC20	M28x1,5
1151	821151AC09	M28x1,5

Matching fittings

For heating systems with copper, polyethylene or multi-layer polyethylene pipes, use the following fittings to connect ICMA thermostatic expansion valves to the heating system:

Article	Fitting Thread
90 - Patented SICURBLOC fitting for copper pipe	G 1/2" - M24x1,5
98 - Fitting for multi-layer, polyethylene pipe	G 1/2"
100 - Fitting for multi-layer, polyethylene pipe	M24x1,5

Technical specifications

Performance

Fluids used:	Water and glycol solutions
Maximum percentage of glycol:	50%
Maximum operating pressure:	10 Bar
Maximum differential pressure:	1 Bar (with control device mounted)
Temp. of heat transfer fluid:	5 ÷ 120°C
Valve obturator travel:	3,5 mm
Connection with thermostat control devices:	28 x 1,5

Materials

Body, cap and socket union:	Brass CW617N - UNI 12165
Finish:	Chromed, white, black matt
Large screw:	Brass CW617N - UNI 12164
Spring and obturator control rod:	Stainless steel
Hydraulic seals:	EPDM Perox
Control knob:	ABS

Dimensions and part numbers

Thermostatic valves double angled

1140-1146-1148 SX

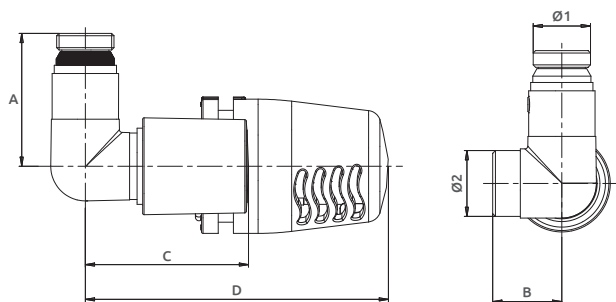

Code	Ø1	Ø2	A	B	C	D
821140AD S 07	G1/2"	M24x1,5	48	25	59	109,5
821142AD S 13	G1/2"	M24x1,5	48	25	59	109,5
821148AD S 09	G1/2"	M24x1,5	48	25	59	109,5

1140-1146-1149 DX

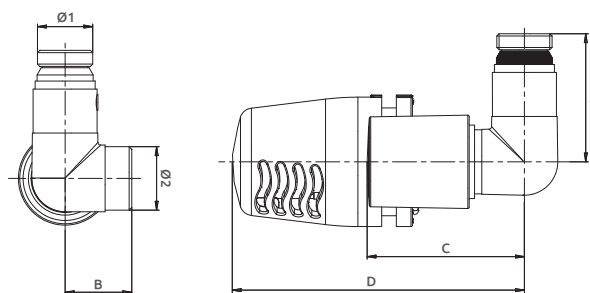

Code	Ø1	Ø2	A	B	C	D
821140AD D 07	G1/2"	M24x1,5	48	25	59	109,5
821142AD D 13	G1/2"	M24x1,5	48	25	59	109,5
821148AD D 09	G1/2"	M24x1,5	48	25	59	109,5

Lockshields double angled

1143-1147-1149 SX

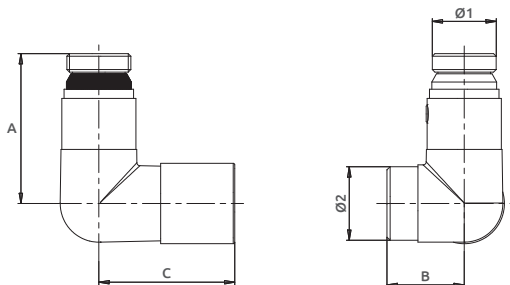

Code	Ø1	Ø2	A	B	C
821143AD S 07	G1/2"	M24x1,5	48	25	44
821147AD S 13	G1/2"	M24x1,5	48	25	44
821149AD S 09	G1/2"	M24x1,5	48	25	44

1143-1147-1149 DX

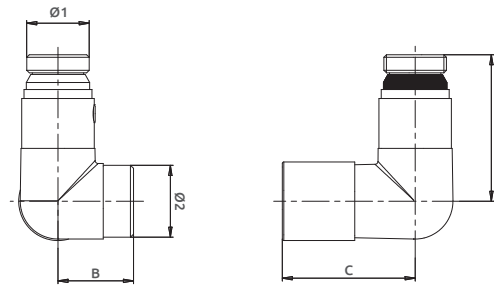

Code	Ø1	Ø2	A	B	C
821143AD D 07	G1/2"	M24x1,5	48	25	44
821147AD D 13	G1/2"	M24x1,5	48	25	44
821149AD D 09	G1/2"	M24x1,5	48	25	44

/ Right or left version choice guide

In order to help in left or right version choice of our double angle valves and lockshield, please follow examples below with specific notes:

HYDROTHERMAL SYSTEM INSTALLATION EXAMPLE



LEFT VALVE

RIGHT SHIELDLOCK



LEFT SHIELDLOCK

RIGHT VALVE

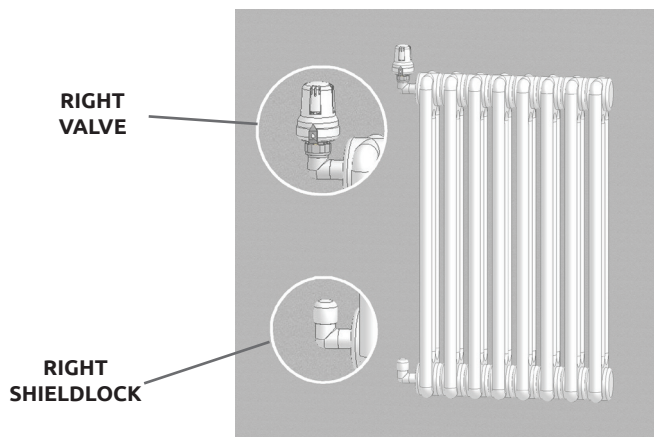

RIGHT VALVE

RIGHT SHIELDLOCK

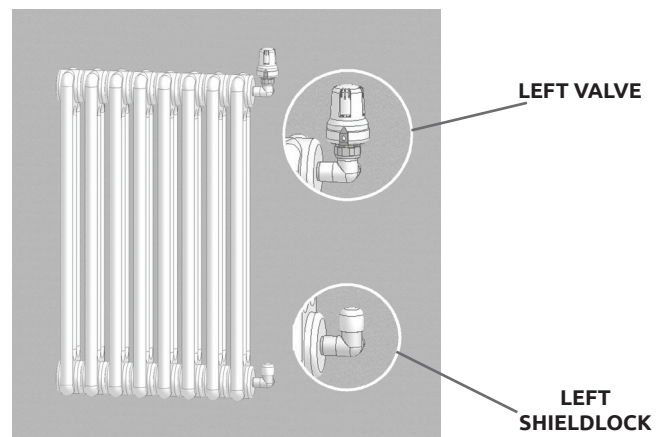

LEFT VALVE

LEFT SHIELDLOCK

Thermostatic control device

Thermostat control devices are used to regulate ambient temperatures automatically wherever they are installed so that the temperature is kept at a preset value.

Residential and working environments often contain other sources of heat, such as electrical appliances, stove-top cookers, computers, servers, and simple sunlight. Combined with the heating system, these additional heat sources

cause a needless, uncontrolled increase in ambient temperature and the wasting of heat. Thermostat control devices detect variations in ambient temperature in the environments in which they are installed making it possible to keep the heat supplied by the heating system at optimal temperatures and to provide a considerable saving of energy.

The ICMA thermostat control device can be installed on all thermostatic expansion valves of this line.

ICMA valves are supplied with the current manual control knob (for manual operation). The valves can be converted into thermostatic valves that function completely automatically by installing a thermostat control device.

To install the thermostat control device, simply remove the thermostatic expansion valve control knob and replace it with the thermostat control device.

This is done with just a few easy operations. These are described in detail in the paragraph "Thermostat Control Device Installation and Regulation".



Adjustment scale

Adjustment scale: ❄ ÷ 5

Temperature adjustment range: 7 ÷ 28°C

The asterisk ❄ indicates the freezing protection position, which corresponds to 7°C.

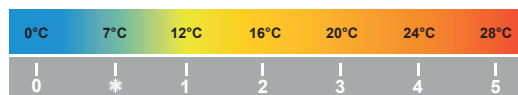

Technical specification

Performance

Minimum adjustment calibration (antifreeze position):	ts min 7°C (❄)
Maximum adjustment calibration (position):	ts max 28°C (5)
Saving condition (position):	20°C (3)
Maximum working pressure:	PN 1000 KPa
Maximum differential pressure:	Δp 100 KPa
Nominal capacity "qm N" angled-straight:	qm N 190 Kg/h
Maximum working temperature:	110°C
Maximum storage temperature:	50°C
Hysteresis:	C 0.25 K
Authority:	a 0,9
Response time:	Z 20 min
Differential pressure influence:	D 0,25 K
Water temperature influence:	W 0,7 K
Use of the protection cap:	55°≈1K
Connection to Valves with thermostatic options:	M28x1,5
Certification:	UNI - EN215

Materials

Knob and stop ring:	ABS
Finish:	chromed, white, black matt
Body and transmitter:	PA6 30% F.V.
Sensor liquid:	Thermostatic ethyl-acetate
Connection ring:	Brass CW617N - UNI 12164 - Nickel-plated
Compensation pin:	Brass CW617N - UNI 12164
Compensation pin spring:	SH steel for springs - Phosphated

/ Operation

The thermostat head is made of a series of plastic parts containing a thermostatic component that is sensitive to temperature variations.

Operation of the thermostatic component is based on the expansion of the thermostatic liquid contained inside it:

- when the ambient temperature rises, the thermostatic liquid increases in volume, resulting in the lengthening of the component;
- when the ambient temperature drops, the thermostatic liquid decreases in volume, resulting in the shortening of the component.

The variations in length of the thermostatic component are transmitted to the expansion valve obturator by a small steel rod. These movements constantly regulate the flow of the heat transfer fluid to the heating component so that the temperature set on the thermostat control device remains constant over time.

CLOSED VALVE

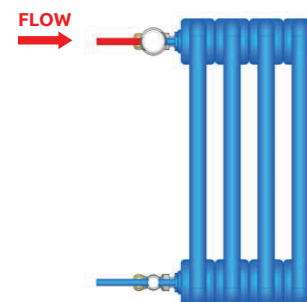

OPEN VALVE

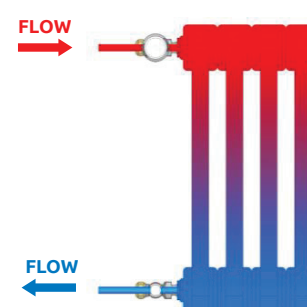

The thermostat control device components are specially made of plastic materials to prevent the valve heat and that irradiated by the heating component from being transmitted to the thermostatic component by contact or induction. This prevents possible malfunctions in the control device.

The thermostat control device temperature is regulated by turning the numbered knob and bringing the corresponding symbol to the desired temperature close to the head indicator (see the following paragraph for more details).

- Position 3 on the adjustment scale corresponds to an ambient temperature of 20°C. This is the recommended temperature for ensuring a comfortable environment and reduced heat consumption and costs.

- The asterisk "❄" indicates the freezing protection position. When the thermostat control device is set to this position, the valve turns on only if the ambient temperature drops below 6°C.

This setting is recommended when one is absent for long period of time during the winter months, or when one wishes to aerate the premises when outside temperatures are very low.

/ Orientation of thermostat control device

The ICMA thermostat control devices should be installed in the horizontal position. Any other position could compromise their correct functioning.

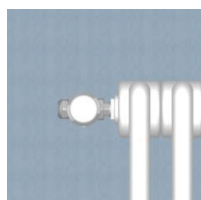

/ Positioning of radiators

The thermostat control devices should never be placed inside niches or radiator boxes, behind curtains or exposed to direct sunlight. These conditions could result in incorrect detection of the actual ambient temperature and compromise the proper functioning of the device.

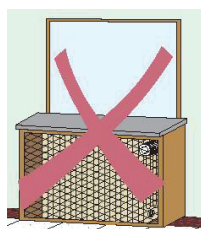

Thermostat control device installation and regulation

Conversion of manual valves to thermostatic valves

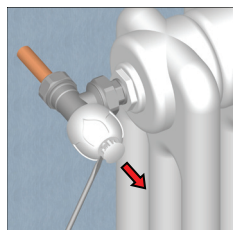

Remove the protective cover from the knob using a small screwdriver.

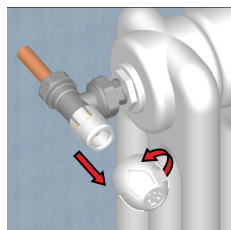

Turn the knob in the counter clockwise direction to remove it completely from the valve.

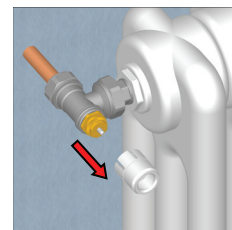

Unfasten the white adapter from the valve body by simultaneously pulling and bending it.

Installation of thermostatic control device

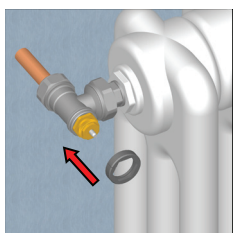

Mount the grey ring supplied with the thermostat control device on the valve body. Keep the hexagonal socket turned toward the operator.

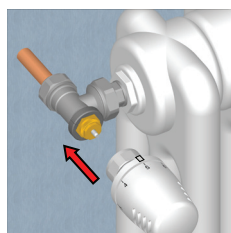

Set the control device to setting 5 and install the device on the valve body. Keep the indicator turned upward so that it is clearly visible.

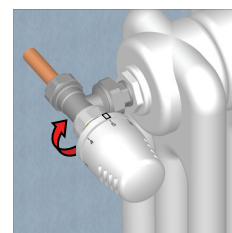

Fasten the thermostatic control device to the valve and screw the chrome-plated ring completely onto the grey ring. Tighten with suitable wrench.



If the use of tools for screwing is necessary, place a soft cloth over the ring to prevent damage to the decorated surfaces.



Temperature adjustment

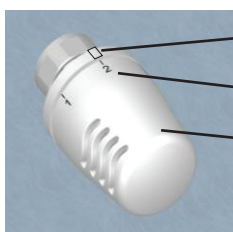

INDICATOR
ADJUSTMENT SCALE
KNOB

The knob indicates the numbers from 0 to 5, which correspond to specific temperatures (see the adjustment scale shown at side).

Set the desired temperature simply by turning the knob to the corresponding number close to the indicator.

0°C	7°C	12°C	16°C	20°C	24°C	28°C
0	*	1	2	3	4	5

Blocking of temperature



Turn the thermostat control device knob to one of the setting numbers from 0 to 5 shown on the knob. Setting example on the n°2.

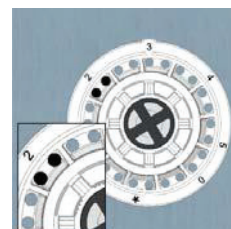

The same numbering is also indicated on the lower part of the device. Identify the hole before and the hole after the number set.



Insert the forked pin inside these two holes and push until completely inserted. The knob is now blocked at the desired setting.

Limitation of temperature

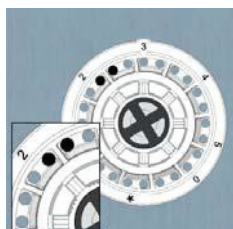

In order to limit the temperature, simply identify the two holes located right after the number set.



Insert the forked pin inside these two holes and push until completely inserted. The knob can now be move from 0 to the number set.



The forked pin is sold separately from the control device.

FORKED PIN CODE: 111100AC06

/ Hydraulic characteristics

Double angled thermostatic radiator valve G3/8" - Art. 1140-1143-1148

PRESSURE DROP DIAGRAM

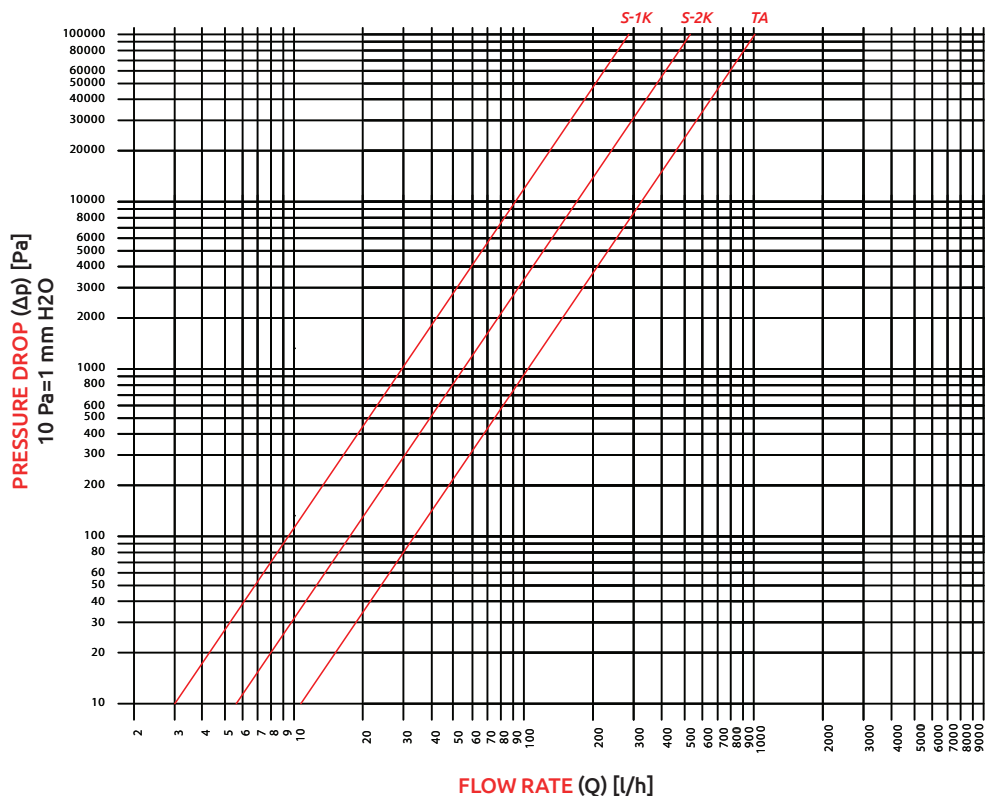

	Kv [m ³ /h]
TA	1,05
S-2K	0,55
S-1K	0,3

Double angled thermostatic radiator valve G1/2" - Art. 1140-1143-1148

PRESSURE DROP DIAGRAM

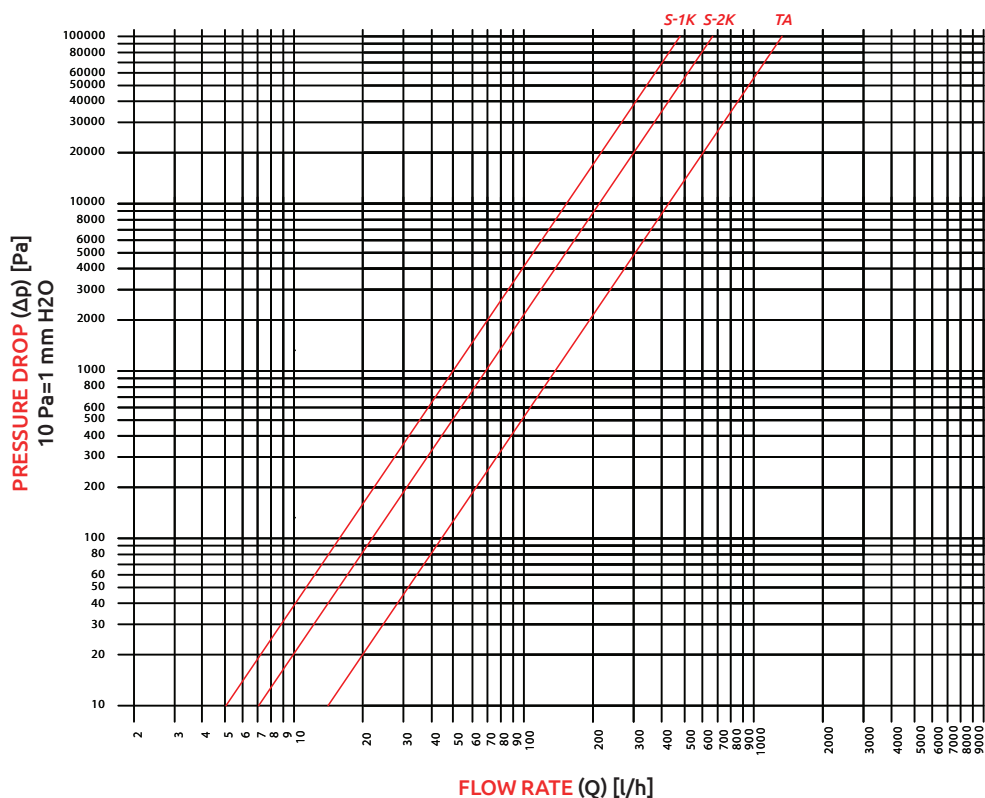

	Kv [m ³ /h]
TA	1,35
S-2K	0,7
S-1K	0,5

Double angled lockshield valve G3/8" - Art. 1146-1147-1149

PRESSURE DROP DIAGRAM

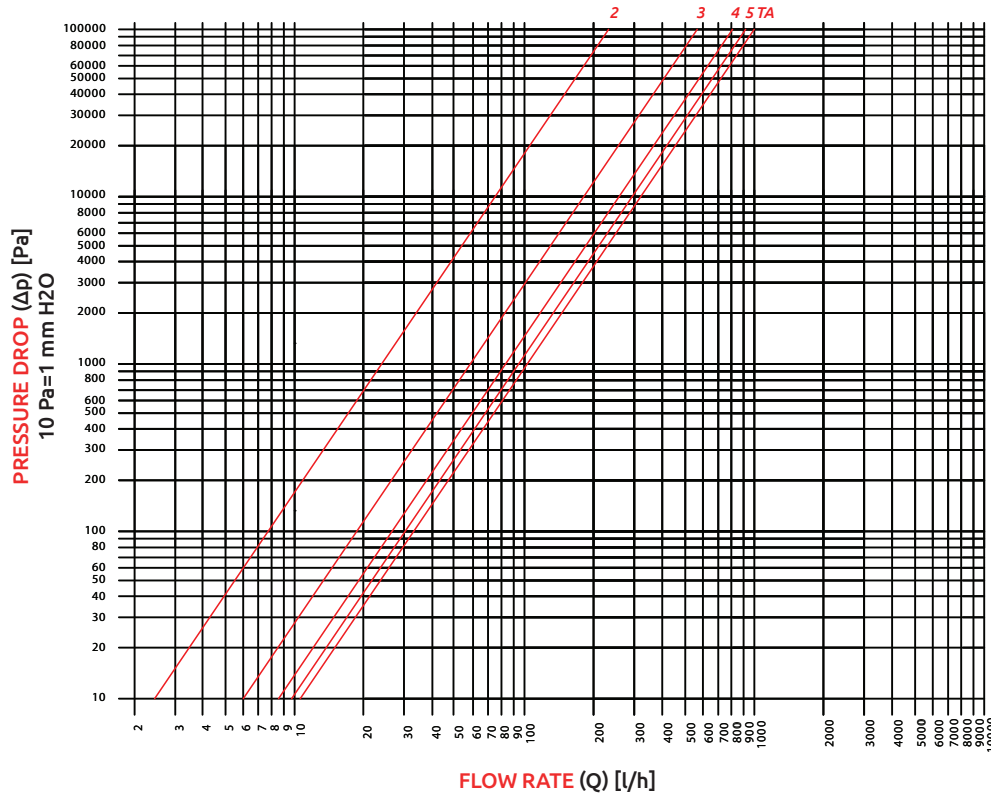

ROUNDS NUMBER	Kv [m ³ /h]
2	0,25
3	0,6
4	0,85
5	0,95
TA	1,05

Double angled lockshield valve G1/2" - Art. 1146-1147-1149

PRESSURE DROP DIAGRAM

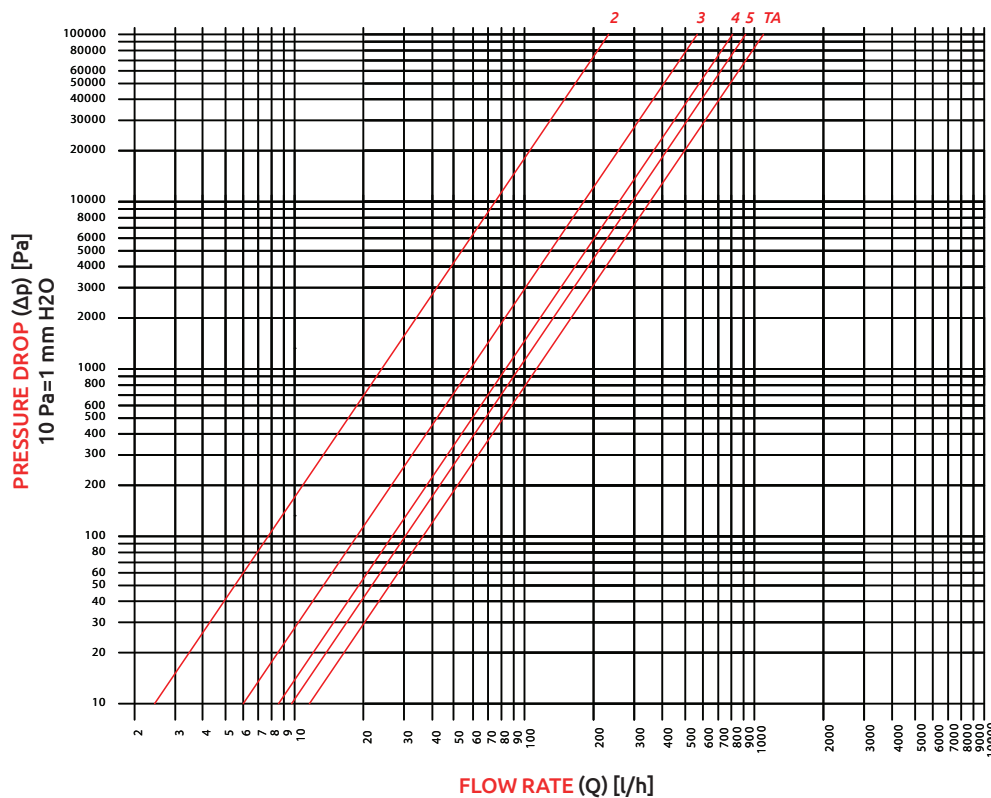

ROUNDS NUMBER	Kv [m ³ /h]
2	0,25
3	0,6
4	0,85
5	0,95
TA	1,15