

/ Function

The solar module is employed in the primary circuits of solar systems to manage the thermodynamic cycle of the heat-transfer fluid between the solar panels and the hot water storage tank. The TAS003 module is also equipped with electronic controllers which, through a sophisticated monitoring system and safety functions, ensures the total protection of the system during its operation. The insulation shell was created to accommodate the electronic controllers S303 and S305.



/ Product range

Art.	Size	Circulator	Circulator control signal		PWM signal cable	Code
			ON/OFF	PWM		
TAS003+S303 ●	3/4"	Grundfos 15/65	√	X	X	TAS003AE05GS303
TAS003+S303 ●	3/4"	Wilo ST 20/6	√	X	X	TAS003AE05S303
TAS003+S303	3/4"	Taco ES2 15-70	√	X	X	TAS003S166S303
TAS003+S303	3/4"	UPM3 15-75 ELECTRONIC CIRCULATOR	√	√	NOT INCLUDED*	TAS003S163S303
TAS003+S303	3/4"	Wilo RSTG 15/7.5 ELECTRONIC CIRCULATOR	√	√	INCLUDED	TAS003S164S303
TAS003+S303	3/4"	Wilo Para ST 15/6 ELECTRONIC CIRCULATOR	√	X	X	TAS003S165S303
TAS003+S303	3/4"	Hefei Xinhua GPA 20-7.5 III	√	√	NOT INCLUDED*	TAS003S167S303
TAS003+S305 ●	3/4"	Grundfos 15/65	√	X	X	TAS003AE05GS305
TAS003+S305 ●	3/4"	Wilo ST 20/6	√	X	X	TAS003AE05S305
TAS003+S305	3/4"	Taco ES2 15-70	√	X	X	TAS003S166S305
TAS003+S305	3/4"	UPM3 15-75 ELECTRONIC CIRCULATOR	√	√	NOT INCLUDED*	TAS003S163S305
TAS003+S305	3/4"	Wilo RSTG 15/7.5 ELECTRONIC CIRCULATOR	√	√	INCLUDED	TAS003S164S305
TAS003+S305	3/4"	Wilo Para ST 15/6 ELECTRONIC CIRCULATOR	√	√	X	TAS003S165S305
TAS003+S305	3/4"	Hefei Xinhua GPA 20-7.5 III	√	√	NOT INCLUDED*	TAS003S167S305

● Products equipped with circulators "Wilo ST 20/6" and "Grundfos 15/6" are intended for sale in non-EU countries.

*To be purchased separately in case of connection with electronic controller with PWM signal.

/ Technical specifications

PERFORMANCE

Fluids used:	Water and glycol solutions
Maximum percentage of glycol:	See circulator specifications page 5
Maximum operating pressure:	10 bar
Calibration of safety valve:	6 bar
Temperature of the heat transfer fluid:	See circulator specifications page 5
Safety valve temperature range:	+160°C
Minimum pressure on the intake side:	See circulator specifications page 5
Opening check valves minimum pressure:	Δp : 2Kpa (200 mm c.a.)
Manometer scale:	0 ÷ 10 bar
Thermometers scale:	0 ÷ 160°C

CONNECTIONS

System connections:	G3/4" M
Safety valve connections :	G1/2" F
Connection with expansion tank:	G3/4" M
Filling/emptying connections with hose:	Ø13 mm

MATERIALI

Brass components:	Brass CW617N - EN 12165
Seals:	PTFE
Sealing elements:	EPDM Perox
Flat seals:	See circulator specifications page 5
Insulation shell:	PPE
Conductivity of insulation shell $\lambda(\Delta T)$:	0.041 (W/mK)

/ Principle of operation

Icma solar module TAS003 is employed in the primary circuits of solar systems to manage the thermodynamic cycle of the heat-transfer fluid between the solar panels and the hot water storage tank.

In thermal solar panels the solar radiation increases the heat-transfer fluid temperature and therefore its thermal power.

In the storage tank, instead, the heat-transfer fluid carries through a heat exchanger most of its heat to the water in the tank.

The hot water in the tank will be then used for space heating or domestic use.

The solar module manage this process and is equipped with a circulator pump having proper performances (flow and head) as well as several regulation and control devices that run the operation of the circuit.

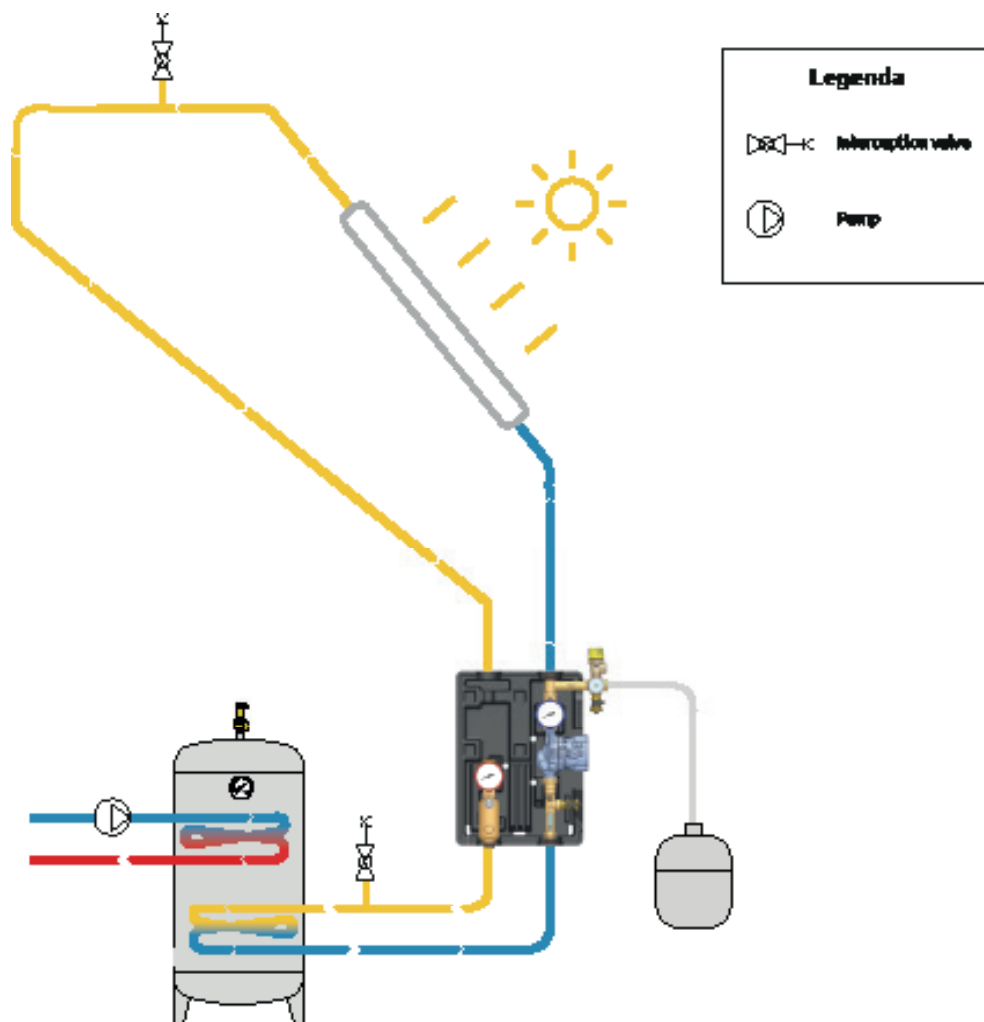

Components

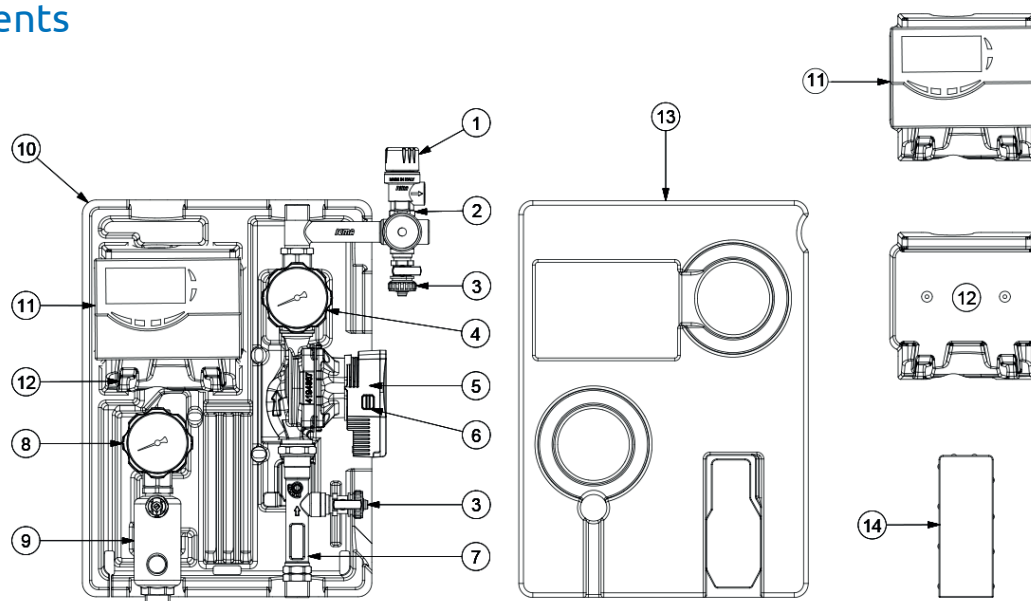

Tab. 1

1. Safety valve for solar energy systems
2. Instrument holder connection with manometer
3. Taps for filling, emptying and washing the system
4. Shut off valve with thermometer and built-in check valve
5. Circulator
6. Pump connector
7. Flowmeter
8. Shut off valve with thermometer and built-in check valve
9. Deaerator
10. Preformed insulating base
11. Electronic controller S303/S305
12. Hose connection
13. Preformed insulating cover
14. Inspection compartment insert

Dimensione

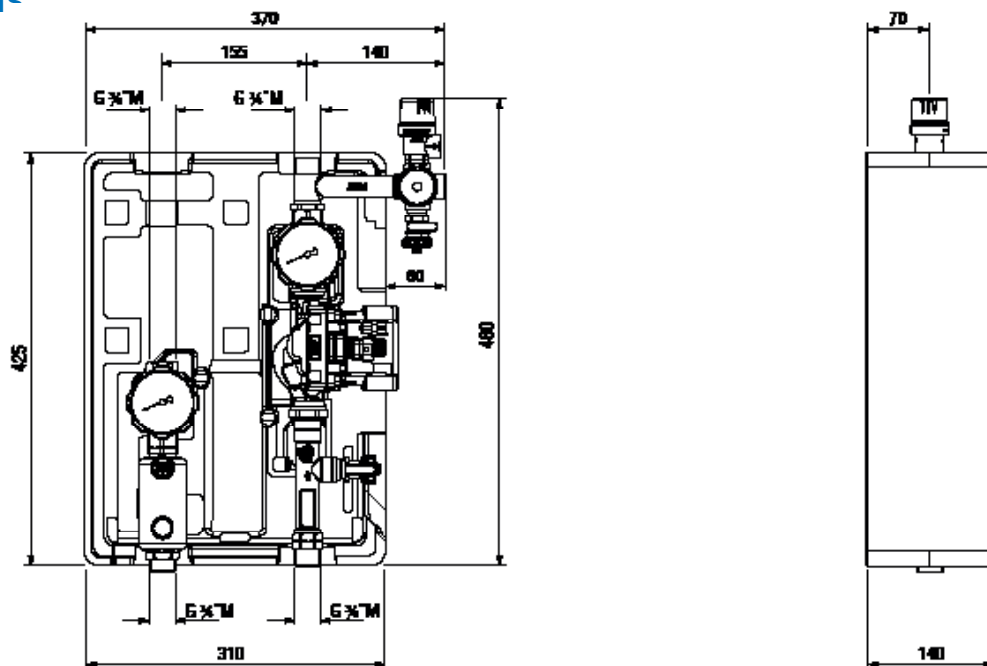

Tab. 2

/ Technical specifications

The solar module receive a signal from the external controller which, having at least two temperature sensors (one is positioned on the panel outlet pipe and the other is an immersion sensor in the boiler), constantly reads the temperature difference and keeps it within the established range, which normally varies between 5 and 8 °C. If the Δt between the panel and the boiler is found to be over the established set point, the controller starts up the pump on the module to provide the lacking thermal load. If, on the other hand, the Δt is narrower than the one set, the internal pump will be disabled.

For further clarification about the electronic controller functioning, consult the technical documentation about art. S303 and S305.

/ Circulators range

Art. S160 - Synchronous circulation pump with 3 speeds



Technical specifications

Brand:	Wilo
Model:	Solar ST20/6
Centre to centre distance	130 mm.
Connections:	G1" M
Flat seals:	Cellulosic fibers with NBR
Electrical power supply:	230 V - 50/60 Hz
Operating temperature:	2 ÷ 110°C
Max temperature:	140°C for short periods
Max operating pressure:	10 bar
Protection level:	IP44
Energy class (EEI):	C
Maximum percentage of glycol:	50%
Minimum pressure on the intake side:	0,049 bar

HYDRAULIC CHARACTERISTICS

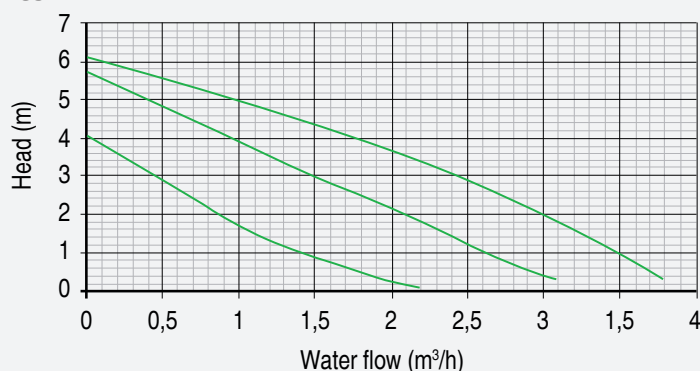

Art. S160G - Synchronous circulation pump with 3 speeds



Technical specifications

Brand:	Grundfos
Model:	Solar 15/65
Centre to centre distance:	130 mm.
Connections:	G1" M
Flat seals:	Cellulosic fibers with NBR
Electrical power supply:	230 V - 50/60 Hz
Operating temperature:	2 ÷ 110°C
Max temperature:	140°C for short periods
Max operating pressure:	10 bar
Protection level:	IP44
Energy class (EEI):	C
Maximum percentage of glycol:	50%
Minimum pressure on the intake side:	
• T=85°C	0,049 bar
• T=90°C	0,270 bar
• T=110°C	1,080 bar

HYDRAULIC CHARACTERISTICS

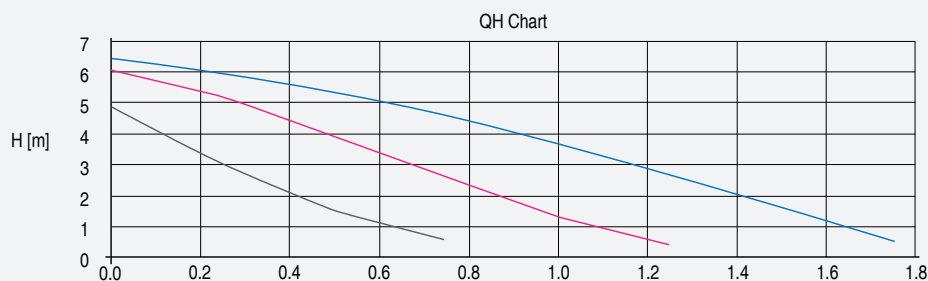

Art. S163 - Circulator with 4 constant curves, 4 PWM curves profile C



Technical specifications

Brand:	Grundfos
Model:	UPM3 SOLAR 15-75 130
Centre to centre distance:	130 mm.
Connections:	G1" M
Flat seals:	Cellulosic fibers with NBR
Electrical power supply:	230 V - 50Hz
Working temperature (cast iron body):	2 ÷ 110°C
Working temperature (PPS body):	2 ÷ 95°C
Max temperature (cast iron body):	130°C for short periods
Max operating pressure:	10 bar
Protection level:	IPX4D
Energy class (EEI):	≤0.20
PWM signal cable code:	C64P3280153 (NOT INCLUDED)
Maximum percentage of glycol:	50%
Minimum pressure on the intake side:	
• T=75°C/95°C/110°C	0,050 bar

HYDRAULIC CHARACTERISTICS

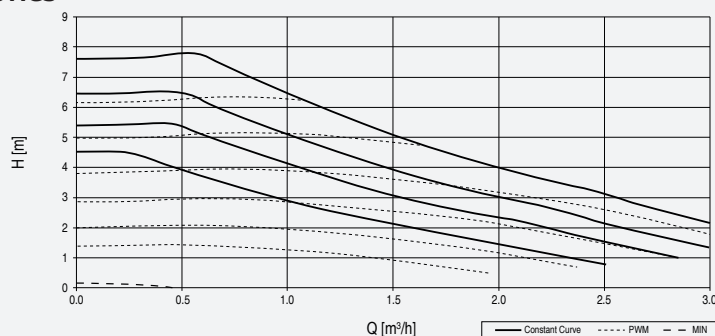

Art. S165 - Circulator with 3 constant curves, ΔP variable



Technical specifications

Brand:	Wilo
Model:	Para 15-6
Centre to centre distance:	130 mm.
Connections:	G1" M
Flat seals:	Cellulosic fibers with NBR
Electrical power supply:	230 V - 50/60 Hz
Operating temperature:	
• Ambient temperature = 58°C	2 ÷ 100°C
• Ambient temperature = 62°C	2 ÷ 90°C
• Ambient temperature = 66°C	2 ÷ 80°C
• Ambient temperature = 71°C	2 ÷ 70°C
Max operating pressure:	10 bar
Protection level:	IPX4D
Energy class (EEI):	≤0.20
Maximum percentage of glycol:	50%
Minimum pressure on the intake side:	
• T=85°C	0,049 bar
• T=90°C	0,270 bar

HYDRAULIC CHARACTERISTICS

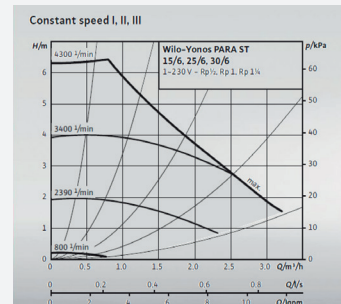
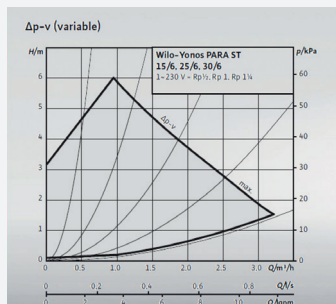

Art. S164 - Circulator with 3 constant curves, ΔP variable, 2 PWM curves



Technical specifications

Brand:	Wilo
Model:	Yonos PARA RSTG 15/7.5 RK
Centre to centre distance:	130 mm.
Connections:	G1" M
Flat seals:	Cellulosic fibers with NBR
Electrical power supply:	230 V - 50/60 Hz
Operating temperature:	
• Ambient temperature = 52°C	2 ÷ 110°C
• Ambient temperature = 57°C	2 ÷ 95°C
• Ambient temperature = 60°C	2 ÷ 90°C
• Ambient temperature = 67°C	2 ÷ 70°C
Max temperature:	130°C for short periods
Max operating pressure:	10 bar
Protection level:	IPX4D
Energy class (EEI):	≤0.21
Maximum percentage of glycol:	20%
Minimum pressure on the intake side:	
• T=50°C	0,049 bar
• T=95°C	0,441 bar
• T=110°C	1,079 bar

HYDRAULIC CHARACTERISTICS

$\Delta p-v$ (variable)

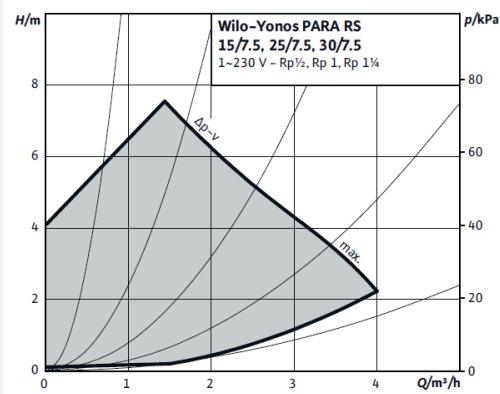

$\Delta p-v$ (variable)

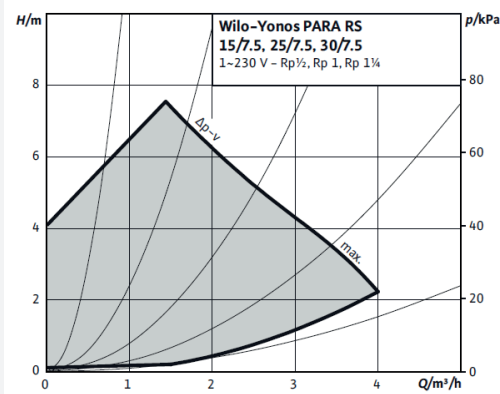

External control via PWM 1

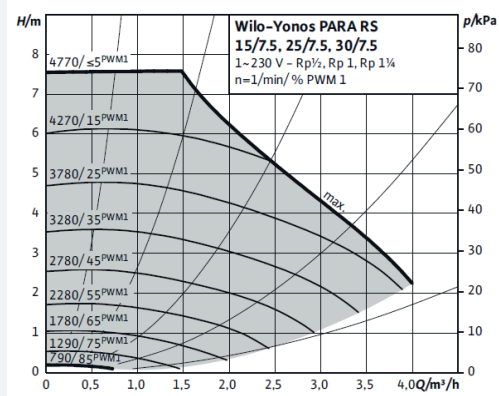

External control via PWM

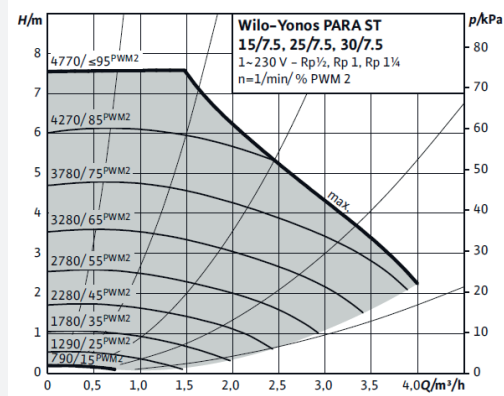

Art. S166 - Circulator with 1 proportional-pressure curve - min-max mode – Fixed speed



Technical specifications

Brand:	Taco
Model:	ES2 solar 15-70
Centre to centre distance	130 mm.
Connections:	G1" M
Flat seals:	Cellulosic fibers with NBR
Electrical power supply:	230 V - 50/60 Hz
Operating temperature:	
• Ambient temperature = 30°C	30 ÷ 110°C
• Ambient temperature = 35°C	35 ÷ 90°C
• Ambient temperature = 40°C	40 ÷ 70°C
Max operating pressure:	10 bar
Protection level:	IP44
Energy class (EEL):	≤0.21
Maximum percentage of glycol:	50%
Minimum pressure on the intake side:	
• T=85°C	0,049 bar
• T=90°C	0,270 bar
• T=110°C	1,080 bar

HYDRAULIC CHARACTERISTICS

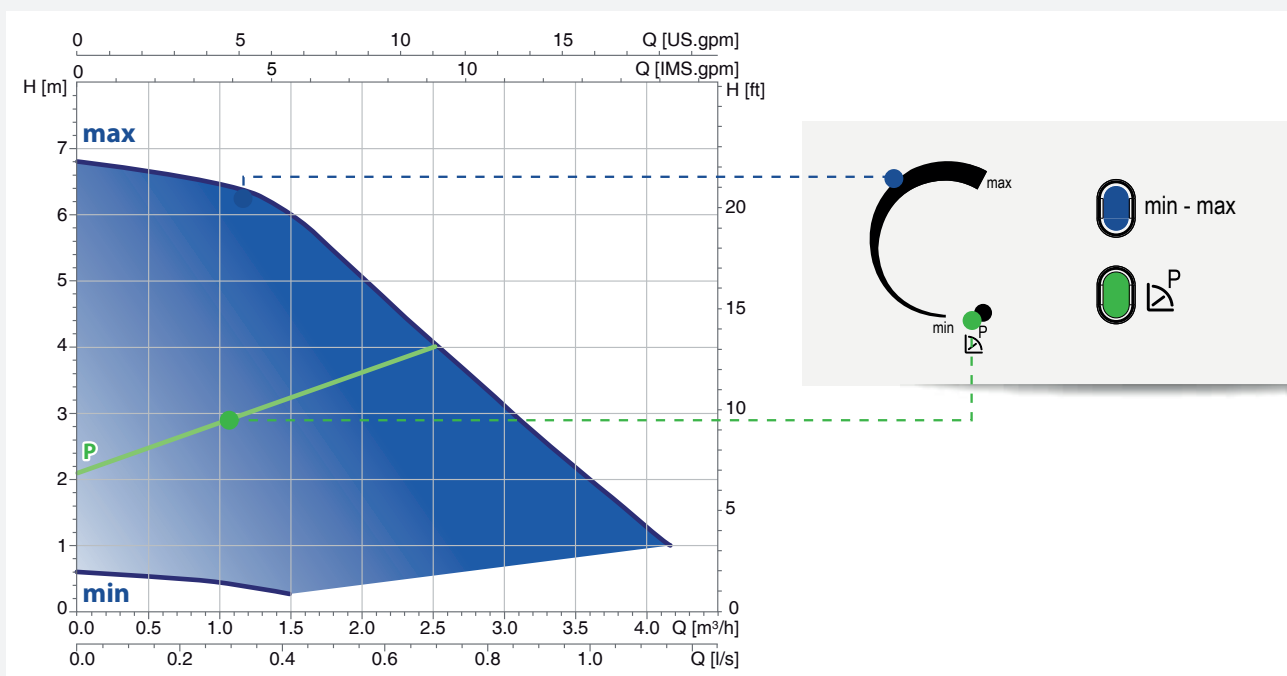

Art. S167 - Circulator with 3 constant curves, 3 PWM curves



Technical specifications

Brand:	Hefei Xinxu
Model:	GPA 20-7.5 III
Centre to centre distance:	130 mm.
Connections:	G1" M
Flat seals:	EPDM
Electrical power supply:	230 V - 50/60 Hz
Operating temperature:	
• Ambient temperature = 30°C	30 ÷ 110°C
• Ambient temperature = 50°C	50 ÷ 110°C
• Ambient temperature = 70°C	70 ÷ 100°C
Max operating pressure:	10 bar
Protection level:	IP44
Energy class (EEI):	≤0.20
PWM signal connector code:	C65S1670153 (NOT INCLUDED)
Maximum percentage of glycol:	50%
Minimum pressure on the intake side:	
• T=75°C	0,05 bar
• T=90°C	0,5 bar
• T=110°C	1,08 bar

HYDRAULIC CHARACTERISTICS

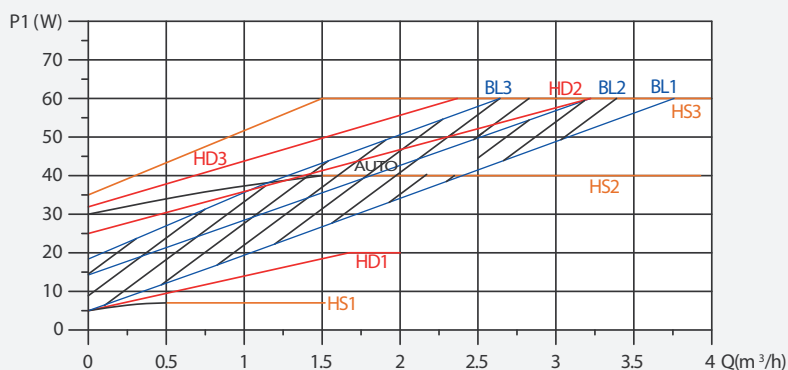
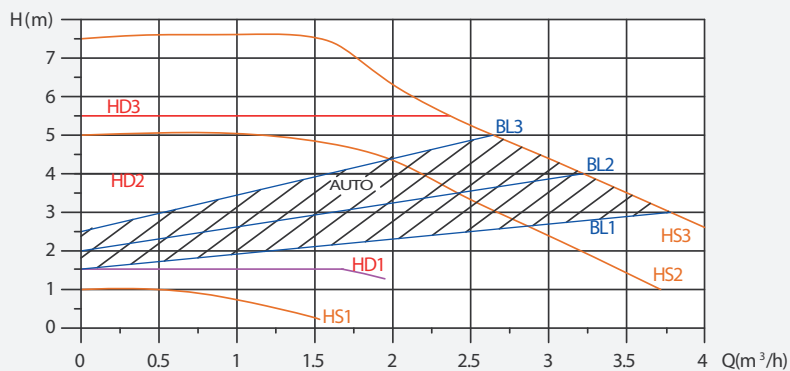

/ Flow meter

The flowmeter 7 (Table1-page 4) is an instrument to measure the flow of the heat-transfer fluid circulating in the system.

It is possible to read in real time the value of the flow in the circuit with the flow indicator (Pict.3), This device is equipped with a glass having a graduated rate of flow scale, with a calibration spring and with a movable indicator that varies its position according to the flow inside the glass. The flow rate reading are explained the paragraph below.

The flow meter is also equipped with a manual flow regulator, adjustable with a screwdriver.

For proper operation, the flow meter must be installed in a vertical position.

The scale range is 0-12 l/min.

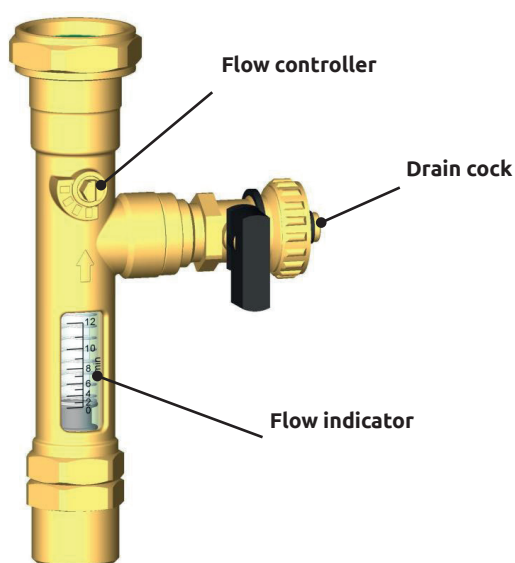

Pict. 3

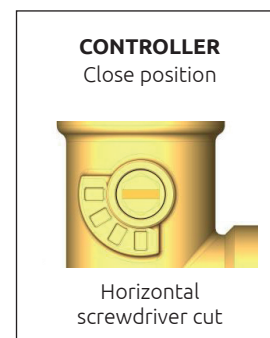
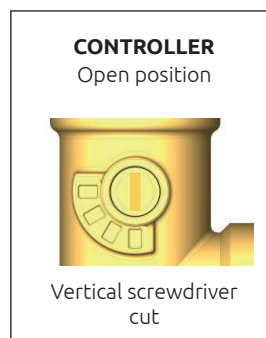

/ Flow rate reading

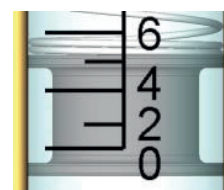
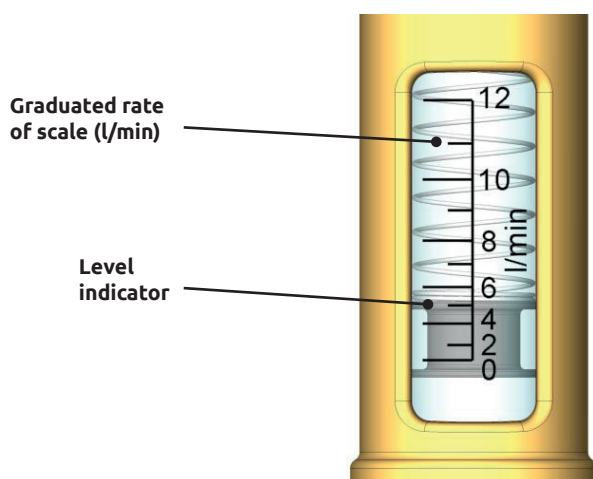

← Example of reading: 5 l/min

Pict. 4

/ Safety

Read assembly and operating instructions carefully before starting up the system in order to prevent accidents and damage to the system caused by improper use. Remember that your rights under the warranty will be forfeited if you make any changes to the system or tamper with it during assembly and construction without authorisation. In addition, you must follow the requirements of the regulations listed below:

/ Operating conditions

The limits on operating values specified must not be exceeded under any circumstances. Safe operation is guaranteed if you comply with the general conditions and limits on operating valves described in this information sheet.

/ Safety standards for assembly and inspection

Assembly and inspection operations must always be performed by qualified, authorised personnel familiar with the instructions contained herein. Make sure the system is shut down before performing any work on it.

/ Electrical connections

Electrical connections must be made by qualified personnel. Connecting cables must be positioned in the cavity provided for the purpose in the insulating shell so as to avoid contact with the body of the pump motor and with pipes.

Check that the power supply voltage is as specified on the plate before turning on the pump. All connections must be made as required by law.

/ Maintenance

Maintenance work must always be performed by qualified, authorised personnel familiar with the instructions contained herein. Make sure the system is shut down before performing any work on it. When replacing the pump, turn the on/off valve, return connection 4 (Table 1-page 3) and flow control valve 7 (Table 1-page 3) to the off position.



WARNING! Depending on operating conditions in the pump and the system, the surface temperature could be very high. Touching the pump directly comports a risk of burning!